



GOLD

GOLD BOOK

Financial Strategy for the Federation

Version 1.0 – April 2026

MANUAL

IFATCA is the recognised international organisation representing air traffic controller associations. It is a non-political, not-for-profit, professional body that has been representing air traffic controllers for more than 50 years, and has more than 50,000 members in over 120 countries.

Printed and published by:

International Federation of Air Traffic Controllers' Associations

The IFATCA Office
360 St. Jacques, Suite 2002
Montreal (Quebec) H2Y 1P5
Canada

Phone: +1 514 866 7040

Fax: +1 514 866 7612

E-mail: office@ifatca.org

DISCLAIMER: The information contained in this document reflect the most up-to-date data available at time of the last amendment. Although every effort has been made to ensure accuracy, neither the International Federation of Air Traffic Controllers' Associations (IFATCA), nor their Members or Officers or representatives, shall be responsible for loss or damage caused by errors, omissions, misprints or misinterpretation of the contents hereof. Furthermore, IFATCA expressly disclaims all and any liability to any person whether a purchaser of this publication or not, in respect of anything done or omitted, by any such person in reliance on the contents of this publication.

COPYRIGHT: The materials herein are copyright IFATCA. No part of this document may be reproduced, recast, reformatted or transmitted in any form by any means, electronic or mechanical, including photocopying or any information storage and retrieval system, without the prior written permission from IFATCA.

Document Control Details

DOCUMENT OWNER	Executive Vice President Finance	evpf@ifatca.org
MASTER COPY HOLDER	Office Manager	office@ifatca.org

Updates and corrections for this manual should be provided to the document owner.

Document Change Summary

Version	Date	Changes
1	April 2026	Initial version.
2		
3		
4		
5		
6		
7		
8		
9		
10		
11		
12		
13		
14		
15		
16		
17		
18		
19		
20		

Table of Contents

1. Executive Summary	3
2. Organization Structure and Representation	4
3. Analysis.....	6
4. Finances.....	9
5. Investment Plan	11
6. Financial Enhancements.....	12
7. Recommendations	13

1. Executive Summary

- 1.1. There has been no clear and defined strategic financial plan beyond the current and following financial year for a considerable period. As such, there has been a lack of focus looking towards the horizon and, therefore, any coherent assessment of where IFATCA is now and where it would like to be in five years' time.

- 1.2. The purpose of this document is to address the lack of long-term strategy. Through identifying key individuals, analyzing of the organization, recognizing potential opportunities, and planning, the Executive Board will be able to present to the IFATCA membership a strategic plan for the future of IFATCA finances.

2. Organization Structure and Representation

- 2.1. IFATCA is a not-for-profit organization based in Montreal, Canada, representing Air Traffic Controllers from across the world. Professional bodies for ATCOs — normally but not exclusively, organized by countries — gain membership of IFATCA by satisfying the requirements of membership laid down in the IFATCA Constitution and Administrative Manual¹. They are then elected by the current Member Associations during the Annual Conference. These Member Associations form the Federation.
- 2.2. Day to day administration of IFATCA rests with the Executive Board. However, during the Annual Conference this responsibility is handed to Directors, a representative of each member association.
- 2.3. Major strategic decisions are made at the Annual Conference with each Member Association entitled to one vote regardless of the size or location of their own membership. Recommendations for decisions are contained in various working papers and come from the Executive Board, IFATCA Standing Committees, or Directors themselves.
- 2.4. **The structure of IFATCA is found in the diagram below:**

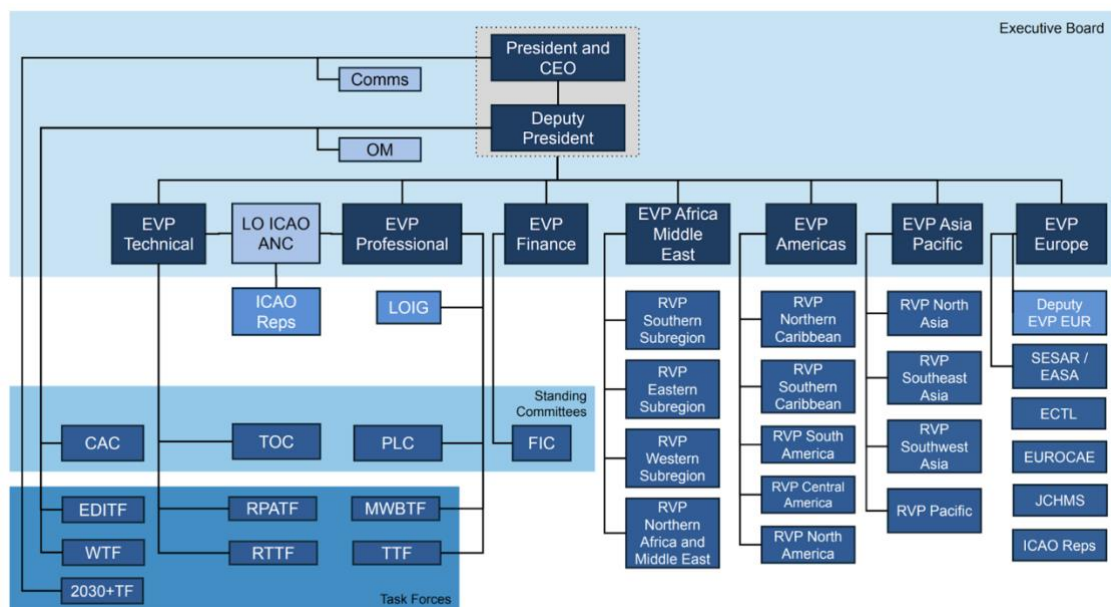

Figure 1: IFATCA Organization Wire Diagram

- 2.5. Members of the Executive Board, nominated by their home MA, are elected by Directors at the Annual Conference for a two-year term. Election of half the Executive Board is conducted in alternate years to ensure continuity and retention of corporate knowledge. The Office Manager is the sole employee of the Federation and is based in Montreal.
- 2.6. Four Standing Committees support the Executive Board by conducting research into various topics and present working papers at the Annual Conference. CAC is responsible for

¹ IAM Part 1, Article 2.2.

constitutional and administrative subjects, FIC for finance, PLC for professional and legal matters, and TOC for technical and operational subjects. Members for each committee are drawn from the Member Associations (MAs) and are elected at the Annual Conference for a one-year term. Each committee is headed by an elected Chairperson who coordinates the work of each committee and is responsible as such to the relevant EVP.

2.7. Makeup of the Executive Board:

- President and CEO
- Deputy President
- Executive Vice President Finance
- Executive Vice President Professional
- Executive Vice President Technical
- Executive Vice President Africa/Middle
- Executive Vice President Americas
- Executive Vice President Asia/Pacific
- Executive Vice President Europe
- Liaison Officer to the ICAO ANC (Ex Officio board member)
- Communications Coordinator (Ex Officio board member)
- Office Manager (Ex Officio board member)

3. Analysis

3.1. Strengths

- 3.1.1. IFATCA has a geographically strong membership base. Split into regions, all continents are represented. As such, it can tap into a vast array of knowledge, experience, and talent so that it can reach its goal of representing Air Traffic Controllers across the globe. As a respected international professional organization, it can influence at a variety of levels including global, regional, and local, in the form of commissions, committees, working groups, task forces, and projects.
- 3.1.2. At present, it is the only established and credible professional organization representing Air Traffic Controllers at a global level.
- 3.1.3. The commonality of profession allows for a high degree of camaraderie amongst members which allows for relationships to grow and for exchanges of information to occur. This also provides an environment where healthy discussions can occur, and opinions are freely expressed.
- 3.1.4. With a large membership and a long history, the Federation has accrued a large amount of funds which in the past has been governed by the Executive Board through shrewd stewardship. This would allow IFATCA to maintain its commitments for at least two years should income cease.
- 3.1.5. There are good working relationships with similar organizations within the aviation community such as IFALPA, IFATSEA, ECA, and IFAIMA, as well as other organizations such as ICAO, IATA, ITF, SESAR, and CANSO.

3.2. Weaknesses

- 3.2.1. Almost all the work of IFATCA is undertaken by volunteers. Therefore, the reliance on individuals to commit time to IFATCA is reliant on many considerations outside of the control of IFATCA such as personal time, family commitments, motivation, and employers. This area applies to all positions from the Executive Board to individual representatives.
- 3.2.2. Almost all the financial income for the Federation is generated by payment of membership subscriptions. The reliance upon prompt payment is paramount to ensure that the financial plan for the year, the budget, is discharged as planned.
- 3.2.3. Further, notable income comes from the work of SESAR, industry partners, and some bank interest. The SESAR work is subject to contracts and is invoiced directly to SESAR for various research projects. Many IFATCA activities within Europe are supported by these contracts and tie directly into the budget.
- 3.2.4. The Federation has only one employee, the Office Manager based in Montreal. This individual has been in the employment of IFATCA for 20 years and therefore retains a high level of corporate knowledge. Although under contract, they have a notice period which means that their departure would be relatively short.
- 3.2.5. The Federation operates with the US dollar as its currency which means unavoidable bank conversion fees. A currency risk is also incurred if other currencies are held in large amounts.

3.3. Opportunities

- 3.3.1. IFATCA has access to a multitude of ATC/ATM experience and knowledge from across the world. This allows the Federation to participate in future developments such as unmanned aerial systems, airspace, emerging technology, and environmental developments, etc.
- 3.3.2. Furthermore, these attributes could be leveraged to enable IFATCA's expertise to support external initiatives. Providing companies and organizations with access to the professional knowledge and experience of Air Traffic Controllers may create opportunities that are beneficial to IFATCA while assisting stakeholders in the development of equipment, systems, studies, and operational procedures, policies, or protocols.
- 3.3.3. The human element in ATC/ATM is a critical aspect of the profession, and developing personnel is essential to maintaining safety performance. In this context, the delivery of training courses supports that development. Although several IFATCA courses are available and well received, they are currently not accredited. Undertaking an accreditation process could be valuable and increase the attractiveness of these courses to prospective participants. While some courses are assessed as nearing maturity, the aspiration should be for all courses to be fully developed, with new courses researched and established as appropriate.
- 3.3.4. As the voice of ATCOs internationally, IFATCA's profile could be further elevated. Leveraging media outlets and collaborating with academia are examples of how this could be achieved.

3.4. Threats

- 3.4.1. A significant reduction or cessation of income would severely limit IFATCA's operations and could call the continued existence of the organization into question. Restrictions on activity would diminish IFATCA's relevance and influence. Such a scenario could be triggered by a major natural phenomenon, such as a pandemic or catastrophic environmental event, the collapse of the civilian aviation industry, or the emergence of technology that reduces or eliminates the need for human involvement.
- 3.4.2. A reduction in membership would also impact cash flow. This could occur through smaller Member Associations, suspensions or terminations of membership, industrial pressures and tensions, or resignations.
- 3.4.3. The emergence of a similar organization could offer an alternative means of representation. At present, only one such organization exists, and it currently has few Member Associations. However, some of these associations are among the largest in the world and presently hold membership in both organizations.
- 3.4.4. Reputation and credibility are earned through sustained effort. Should IFATCA lose either due to a mistake, an intentional or malicious act, criminal activity, or poor work performance, there could be serious consequences, including loss of income as Member Associations depart, diminished influence and relevance, reduced confidence in the organization, and ultimately the potential collapse of IFATCA.
- 3.4.5. Internal cohesion at all levels is essential to achieving the aims of the Federation. Division and friction erode the effectiveness of the area experiencing tension. While healthy debate and the sharing of opinions are encouraged, stepping beyond this can destabilize the harmony that has been built over the years. The result may be distraction from core tasks,

division among the membership, incoherent management, reduced trust, and confusion for those unaware of the issue.

- 3.4.6. A lack of volunteers and/or support of employers, family, and home Member Association could impact IFATCA’s output. As mentioned, volunteers are the backbone of the Federation at all levels. Without them, IFATCA could not exist. However, volunteers must be committed. A lack of commitment can be damaging and increase the workload of others; in extreme cases, it may even lead to the consequences outlined in 3.4.5. The same concern applies to volunteers who lack conventional people and management skills.
- 3.4.7. The collapse of IFATCA’s banking partner, RBC, although unlikely, could restrict access to cash, reduce online services, and ultimately affect IFATCA’s ability to meet its financial obligations. Similarly, a failure of online expense management or accounting tools would increase workloads and stress on the Federation’s financial functions, delaying payments and the recording of transactions. In addition, in the unlikely event that IFATCA’s accounting or auditing partners fail, there could be an increased risk of errors in the recording of IFATCA’s finances.
- 3.4.8. The Federation operates with the United States dollar as its primary currency. Recent political uncertainty in the United States has prompted consideration of whether the USD will retain its status as the world’s reserve currency over the long term.



Figure 2: SWOT Analysis Diagram

4. Finances

- 4.1. IFATCA holds cash assets and investments with the Royal Bank of Canada with the balances reported to directors each year. These bank accounts and investments with RBC include two accounts in Canadian Dollars (CAD) that furnish IFATCA Office functions such as rent, salary, employee benefits, office consumables, and telephone and internet services. A primary account in US Dollars is the main working account that services the CAD accounts, funds any claims from representatives of IFATCA, and harbors the IFATCA Funds. To facilitate card payments from Square, a further CAD account acts as a means of transferring money into the IFATCA finances. Lastly, a Euro account provides a destination for payments from the SESAR project which is also held with RBC as a foreign currency account.
- 4.2. Currently, the breakdown of account balance is referenced for directors at conference each year.
- 4.3. Wire transfers from IFATCA's accounts attract a fee for each transaction which is borne by the Federation. Furthermore, any fluctuations in currency exchange rates are also the responsibility of IFATCA. This represents a major and unpredictable outlay for the Federation, as it depends on the level of activity in which IFATCA is involved from year to year.
- 4.4. As mentioned, IFATCA has established a series of funds for differing purposes. The definition for each one can be found within the IAM² and are listed below:
 - ANC
 - CAF
 - Controller Reserve
 - Equipment
 - Legal Contingency
 - Reserve
 - Financial Circumstances
 - Travel Assistance
 - Regional Attendance Meeting
 - Training
- 4.5. Accounting is carried out by professional accountants in accordance with established Canadian rules, regulations, and practices. Between 2019 and 2021, MNP, a reputable company based in Montreal, served as the Federation's accountants. Since 2021, following a review by the Board, BCGO, also a reputable company based in Montreal, has been appointed as the Federation's accountants. The scope of work is contracted, and a set monthly fee is paid for their services. The Office Manager, delegated by the EVPF, maintains daily contact with them and serves as IFATCA's first point of contact.
- 4.6. QuickBooks Online is the platform used to capture and record all IFATCA financial transactions. Both the EVPF and the Office Manager have daily access to the system.
- 4.7. Financial performance and compliance are assured through independent audit. BCGO was appointed as the Federation's auditors in 2021 and operates within recognized and

² IFATCA Administrative Manual, Part 2 Chapter 3

established Canadian auditing frameworks. Daily contact with the auditors is delegated to the Office Manager by the EVPF.

- 4.8. The Financial Year (FY) for IFATCA runs annually from 01 Jun through to 31 May. Audits begin immediately at the end of the FY. During this process, open dialogue between IFATCA and MNP occurs. A draft report is available usually in September, allowing both the Executive Board (EB) and FIC to scrutinize the contents. A final draft report follows in November and is presented to Directors at the IFATCA Annual in a working paper. This allows Member Associations to examine the details and to ask questions before voting to discharge the EB of its responsibilities for the FY.
- 4.9. The last FY Audit Report was for the FY 2020/2021 and was presented to Directors at the IFATCA Virtual Conference in May 2022. The headline finding was that IFATCA finances had a surplus of income over expenditure of 40,5417 USD. This outcome was influenced by the impact of the COVID-19 pandemic.
- 4.10. Financial health and performance have always been measured by the Report of the Auditors, with the IFATCA Executive Board (EB), FIC, and Directors reviewing its contents to establish that understanding. It should be noted that, for a period of several years, the post of EVPF remained vacant. Consequently, the responsibility for overseeing the Federation’s finances fell to the Deputy President in addition to their other duties. During this time, without a dedicated individual responsible for the close monitoring of finances, financial control may have been less than optimal.

4.11. To provide a comparison, the headline figure for each FY, in USD, is shown below:

FY 2020/2021	+405,417
FY 2019/2020	+194,811
FY 2018/2019	-215,494

4.12. The anomaly for FY 2018/2019 coincided with a complete review and consolidation of IFATCA accounts following the appointment of MNP as auditors and accountants. However, this, combined with a temporary loss of oversight, created some difficulties and division within the Federation, particularly among critically minded Member Associations and those responsible for managing the Federation. Honest and open dialogue allowed the Federation to move forward. Large currency fluctuations also affected the EU account during the reporting process.

5. Investment Plan

- 5.1. The investment plan for IFATCA has been developed to maintain a very low risk profile as the Federation begins to invest and diversify its reserves to best support its membership. The Board considered medium risk investment options that could maximize returns but determined that a staged and conservative approach was preferable, following direction received from Directors at the 2025 Conference. Another consideration in developing this plan was the workload required to oversee and assess the investment portfolio, particularly during periods of change in key Federation personnel.
- 5.2. Since the beginning of 2024 the Board has begun to invest in low-risk financial products and reduce the federations currency risk by moving the cash into USD. As of February 2026, the federation has a total of \$300,000 USD invested in 2 GIC (Guaranteed Investment Certificates) with a 3.75% return for 12 months and \$500,000 invested in an RBC Money Market Fund with a variable return of approximately 4.25%.
- 5.3. Over the next 3 years 2026-2029 the investment plane should continue with the lowest risk profile until the board has more data to see if the strategy is the best for the federation. GIC's should be managed by the board and EVP Finance to gain interest returns and stagger any maturity or cash flow risk associated with these investments. The Money Market Fund will be reviewed every quarter by the EVP Finance to assess the returns, any further investment opportunities and any risk profile changes. This investment plan will also be discussed and assessed by FIC to ensure proper oversight.
- 5.4. The longer-term investment plan 3-5 years will look at further low risk diversification to increase the returns on the reserves held by the federation without increasing the risk above a profile agreed by directors. Such investments will be researched and proposed at coming annual conferences as the gold book is reviewed. Investments may include diversifying into products like a Very Conservative Portfolio which would include entry into the equity markets in some way. Any diversification must have the input from an approved reputable financial advisor, FIC and the directors of the federation.
- 5.5. Other investments have been looked at most notably the recent work done by FIC on property investment. This type of investment has been explored several times by FIC in past years but due to the risk profile and non-liquid nature of such an investment it is not something that should form part of IFATCA's investment plan at this time. If in the future there is a change in risk profile or a large benefit to the budget, such as reducing hotel costs in Montreal, this type of investment can be revisited. There was also work done by FIC and recent EVPF's on diversifying investments and reserves in different locations around the world. The difficulty of managing such widespread investments or accounts when all the federations legal entities and accounts presently reside in Canada would result in a large increase to costs and make managing the not-for-profit status more difficult.

6. Financial Enhancements

- 6.1. As noted previously, IFATCA's income is heavily reliant on subscription fees paid by Member Associations. However, when considering potential threats to the Federation, this income stream may prove to be vulnerable. Over the course of the COVID-19 pandemic, IFATCA has been fortunate that, overall, Member Associations were able to meet their financial obligations. That said, non-payments continue to occur, and the Executive Board works to understand the reasons and offer assistance where possible. The Financial Circumstances Fund is available for Member Associations to draw upon, but its funding comes from IFATCA's financial reserves.
- 6.2. Therefore, IFATCA needs to diversify its income and reduce its reliance on this major revenue stream. As noted, the FIC has attempted to identify additional income sources but, to date, has not been in a position to recommend a credible set of options. In the meantime, the Executive Board has held various discussions on the matter, and the preferred solutions are outlined below.
- 6.3. As identified in the SWOT analysis, the Federation has access to Air Traffic Controllers and associated ATM personnel, along with their expertise, knowledge, and experience. These attributes should be leveraged in a structured and professional manner. Accordingly, requests for access could attract a fee, with the amount varying depending on the nature of the request. Examples of such fees include:
- ATM Audit = \$20000
 - Participation on a project = \$2500
 - Input on a project = \$1000
 - Participation as a panelist or speaker = \$500
 - IFATCA Policy disclosure = \$100
 - IFATCA comment = \$100
- 6.4. Although a relatively new income stream, the nature and frequency of such requests are inconsistent and therefore an unreliable source or revenue. Nonetheless, when the opportunity arises, they should not be overlooked. The expertise to which IFATCA has access should not be provided free of charge.
- 6.5. Furthermore, and likely beyond the scope of this document, IFATCA should cultivate professional relationships with mainstream media to raise its profile and become a first point of contact for ATC/ATM commentary. This would also showcase the Federation's ability to provide professional insight on current developments within the industry.

7. Recommendations

7.1. Recommendation 1: Commercially leverage off the expertise that IFATCA has access to.

- 7.1.1. **Industry Partners.** Along with Member Associations, IFATCA has a small but growing Industry Partner program which has been reviewed over the past 3 years and provides income by way of a membership fee; details concerning industry partnership are laid out in the IFATCA Administrative Manual. However, there are three levels of membership with each tier commanding a different fee and benefits. Currently, Platinum is \$3000 per annum, Gold \$1500, and Silver \$750. In addition to their subscription fee, should they wish to exhibit their products at an IFATCA meeting, an additional fee is levied, the same for any advertising.
- 7.1.2. In order to assist with income streams, industry partnership could change. The package could be consolidated or expanded, so benefits to both parties can be explored, such as training courses or joint projects.
- 7.1.3. Industry partners for example could be consolidated to a single tier of \$5000 for the yearly membership. But the new package could include all fees for the opportunity to attend the Annual Conference and all Regional Meetings. The opportunity to participate in industry events or professional or technical events and online events.

7.2. Recommendation 2: Scheduled reviews of the Industry Partner package with partners.

- 7.2.1. **Training courses.** As previously mentioned, IFATCA provides a suite of courses that are available to all MAs. The Think Safety Workshop, and Competency Based Training and Assessment Workshop were both sought after courses prior to the COVID pandemic. Additionally, English Language Proficiency, and Critical Incident Stress Management provided a more bespoke learning opportunity for MAs. At present, none of these IFATCA courses are accredited with any recognized education provider. It should be an aspiration for the Executive Board, specifically EVP Professional, to achieve accredited status. This would allow for reinforcement of the product quality, certificated course completion, and professional course design structure.
- 7.2.2. Successful delivery of the course requires several key requirements to be met to aid in the facilitation. A classroom, furniture, stationary, electrical outlets to support IT equipment, refreshments, lunches, and accommodation are all essential. At present, the cost of this is met by sponsorship and some funding from IFATCA. Additionally, course leaders and facilitators/instructors will have their travel and subsistence paid for by IFATCA as laid out in the IAM.
- 7.2.3. These courses provide individuals the chance for continued personal development, MAs to expand knowledge, ANSPs to also expand and update knowledge and experience, and government transport departments to access current thinking on course topics.
- 7.2.4. Furthermore, this is an opportunity to exploit these courses as an additional form of income. Therefore, it is recommended that each course attracts a participant fee as below:

- Each participant = \$250
- Each individual participant of Tier 3 MA = 100% discount
- Each individual participant of a Tier 2 MA = 75% discount
- Each individual participant of a Tier 1 MA = 50% discount
- Each Corporate Member = 50% discount

7.2.5. To ensure success, and to be financially viable, each course requires a minimum of 20 participants. Some funding will be available from IFATCA financial resources to support each course. The Federation will also be able to assist with gaining sponsorship from industry partners or other organizations.

7.3. Recommendation 3: Redevelop, gain accreditation, and generate revenue for the training courses IFATCA has to offer.

7.3.1. **Annual Conference and Regional Meetings.** The IAM and Constitution dictate that IFATCA requires an Annual Conference in order to conduct, confirm, and report the business of the Federation and involves all MAs. Likewise, Regional EVPs hold regional meetings for their MAs annually, allowing for open discussion on topics and concerns specific to the region.

7.3.2. Organization of such conferences and meetings invariably incurs costs. While some funding is available from IFATCA financial resources, the vast majority of financial liability rests on the organizing committee, typically the host MA or a partnership between the home ANSP and MA. Clearly, this puts potential strain on MAs finances. To offset this, organizing committees regularly seek sponsorship from industry or other avenues within their domestic market. The use of registration fees also provides income to offset the costs of the organizing committee. This in turn makes hosting an IFATCA conference or meeting unattractive due to the financial risks posed and the sheer volume of work required to make it a success.

7.3.3. Such liability shouldn't put an MA at risk. It is therefore recommended that IFATCA look at supporting the MA to reduce any financial risk taken by the host MA. At the earliest possibility, IFATCA should consider increasing the grant paid to organizing committees to better support the host MA. Similarly, a grant for regional meetings should also be explored.

7.4. Recommendation 4: Financial support for Conference and meetings to reduce risk on host MA.

7.4.1. **Investments.** The federation has been able to build a surplus of funds over the last 5 years due to limited travel after the impact of the COVID pandemic.

7.4.2. **Low risk Investments.** The federation has recently invested a portion of these funds in very low risk GICs and a bond portfolio with RBC. These investments are intended to generate moderate interest returns while maintaining sufficient liquidity to ensure the funds remain accessible if required.

7.4.3. **Moderate Risk Investments.** The Federation has not yet moved into higher risk investments; however, there is now an opportunity to look at equity markets and other moderate risk investments to maximize the returns to the federation.

- 7.4.4. **Maintaining Income Generating Funds.** At the 2019 Conference, the Directors instructed the board to maintain a balanced budget each year and present a proposed balanced budget to the Conference each year. As such, the Federation now has the ability to maintain the funds held to generate income and support the annual operating budget. The Federation should hold \$300,000USD in low-risk accessible investments to ensure a minimum operating base in case of unexpected loss of total income so we can service our liabilities. The Federation should start to grow a diversified low risk investment portfolio to generate income and support the yearly operating budget. A goal of having \$1,000,000USD of our funds held invested within 5 years could provide a conservative income of \$50,000USD per annum.
- 7.5. **Recommendation 5: Scheduled reviews of the investment plan through EVPF and FIC with the assistance of professional advice.**
- 7.5.1. **Subscriptions/payments.** The majority of income is provided by the membership subscriptions. This is currently invoiced to MAs annually. The use of categories, groups MAs based on their country classification determined FIC using the World Bank to guide them. The rates are reviewed annually by FIC and a recommendation made as to any increase to be introduced for the coming fiscal year. Directors vote to accept the recommendation at the Annual Conference by way of budget approval.
- 7.5.2. In order for the annual budget to perform correctly, it is incumbent on MAs to ensure that payment of their invoice is made promptly. To facilitate this, several payment methods are available including wire transfer, electronic transfers, credit card payments through Square, and PayPal.
- 7.5.3. However, due to national and international restrictions on financial transactions, some MAs are unable to avail themselves of methods established for payments to the Federation. In the past, these MAs have paid their subscriptions in cash at the Annual Conference. Payment options for MAs continues to be a huge problem in some regions and must be continually reviewed by EVPF and FIC. Fortunately, a pragmatic approach has been taken by both the EB and Directors with any potential suspensions or terminations being deferred if the issues are not of the MAs making.
- 7.5.4. Outside of this unusual situation, it is important for MAs to engage with the EB, through Regional Vice Presidents, should the ability to pay be difficult. Suitable mechanisms and solutions are available to help, and assist should payment be problematic.
- 7.5.5. Ideally, cashless payments are the preferred method. FIC in recent years have investigated many options for payment with the current methods optimum for the time being. That said, the aim is to be completely free of physical cash payments at the earliest opportunity.

7.6. In summary, the recommendations for the financial plan of the federation are:

Number	Recommendation	Lead
1	Explore commercially leveraging off the expertise that IFATCA has access to.	President and CEO
2	Scheduled reviews of the Industry Partners package.	Deputy President
3	Explore the commercialization of the training courses IFATCA has to offer.	EVP Professional
4	Financial support for host MA's conference and meetings.	EVP Finance
5	Scheduled reviews of the investment plan through EVPF and FIC	EVP Finance